

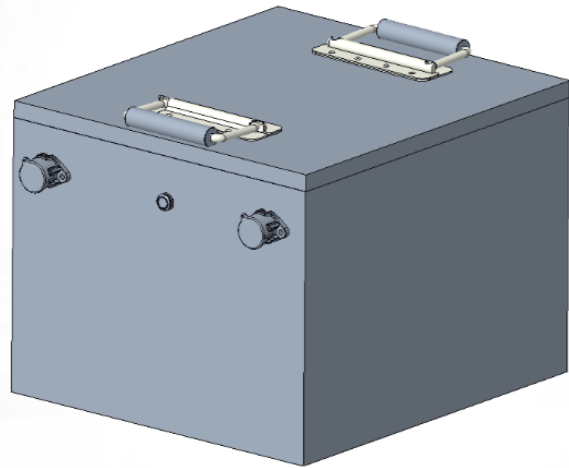

CM series energy power batteries





Introduce

TCSN CM series features high-rate, long-life LFP batteries and an integrated, high-quality BMS. Bid farewell to bulk and embrace efficiency as we redefine power for cleaning equipment; compared to traditional batteries, the volume has been reduced by approximately 30%, freeing up valuable space for equipment design.

Features

 Shock-resistant design
Automotive-Grade Vibration-Resistant Design
Unafraid of Bumps — Rock-Solid Stability

 Safe and worry-free
Using LFP batteries ensures high safety, no fire, and no explosion.

 Worry-Free After-Sales Service
5-Year Standard Warranty
Long-Lasting Protection — Extendable

 Low self-discharge
Significantly Reduced Power Loss During Hibernation
Monthly Self-Discharge $\leq 2\%$

 Long-lasting battery life
For the same volume, battery life is significantly improved.

 High-Efficiency Fast Charging
Supports 1C fast charging.
Standard charging can fully charge the device within 2.5 hours.

Performance

Model	Dubhe CM24-80
Performance	
Cell	Square LFP80Ah
Terminal	M8
IP Grade	IP67
Self Discharge	$\leq 2\%$ /Month
Cycle Life	6000times(80%DOD)
Rated Charge Current	40A
Max. Charge Current	80A
Rated Charge Voltage	27.2~27.6V
Charge Cut-off Voltage	29.2V
Balancing Voltage	$>27.2V$
Rated Discharge Current	40A
Max. Discharge Current	80A
Rated Discharge Cut-off Voltage	22.4V
Min. Discharge Cut-off Voltage	$>20V$
Short Circuit Current	Approx.3000A

Performance parameters	
Capacity	80 Ah(0.5C@25°C)
Nominal Voltage	25.6V
Energy	2048Wh
Weight	~22kg
Dimensions	338*307*228mm
Communication interface	/
LCD Panel	/
Storage Temp	-5°C to 35°C
Discharge Temp	-20°C to 55°C
Charge Temp	0°C to 45°C

Size

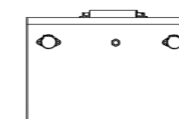
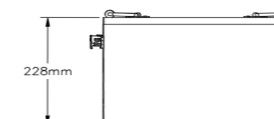
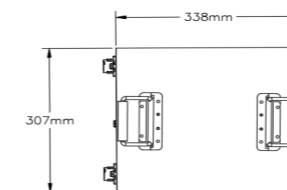

Compliance

Certifications	Cell UN38.3
	Battery UN38.3
Transport Appraisal	UN3480,CLASS 9

System Management Diagram

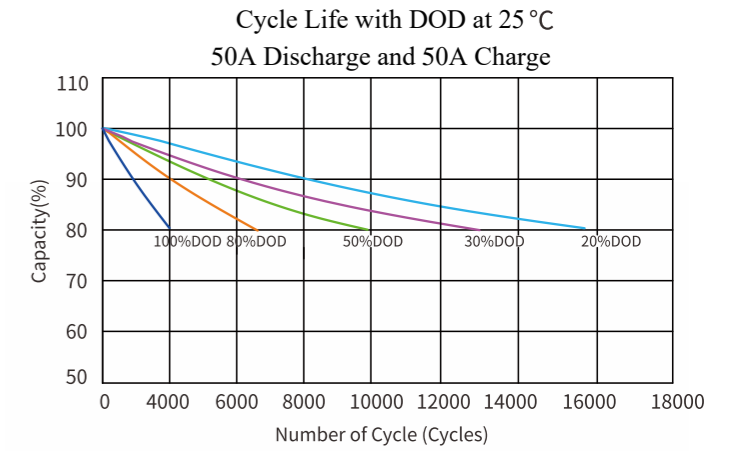
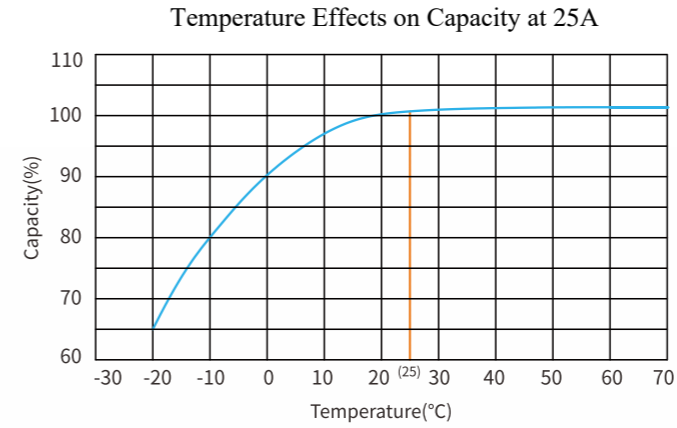
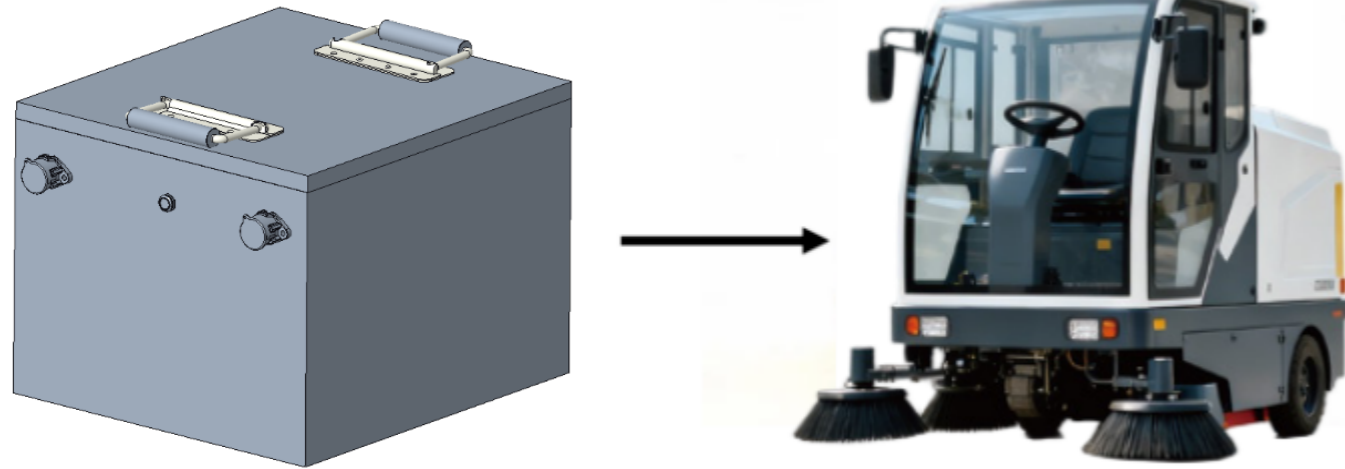

Characteristics Curve

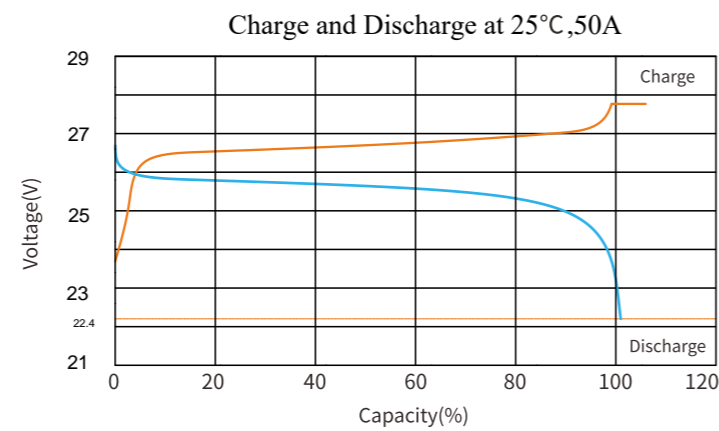
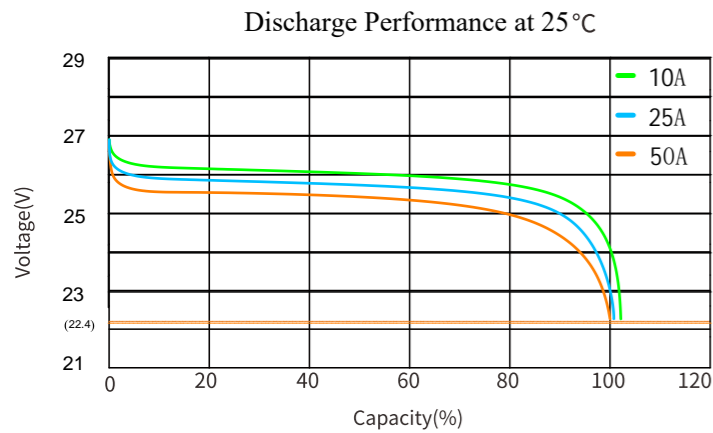

Cautions

1. Do NOT short circuit, crush or disassemble.
2. Do NOT heat or incinerate.
3. Do NOT immerse in any liquid.
4. Store at 50% capacity. Recharge every 3 months. The storage area should be clean, cool, dry and ventilated.
5. Disconnect charging source prior to connecting or disconnecting battery terminals.
6. Do not dispose of batteries in a fire as they can explode.
7. Do not open, alter, or mutilate batteries. Released electrolyte is harmful to skin and eyes. It may be toxic.
8. Do not mix different types and brands of lithium-ion batteries.
9. Do not dispose in trash, follow local regulations and manufacturer's instruction.
10. See installation instructions before connecting to the supply.
11. The battery cabinet receives power from more than one source. Disconnection of all DC sources is required to De-energize this unit before installing or servicing. Wait 5 minutes before opening the unit.
12. Do not install on or over combustible surfaces.
13. Refer to manual before servicing.
14. Do not touch bare terminals.